

# Wheelchair Scale

## Model **SR725i** and **SR725i-L**

Do you have a need for a large weighing platform but don't have the floor space? Then the SR725i may be just what you're looking for.

This scale folds down flat and stores vertically, keeping hallways clear for safety. The aluminum frame is lighter than steel-based platforms and the scale's large weighing surface with integrated ramps easily accommodates patients with walkers, canes, chairs, and wheelchairs. The wider SR725i-L can accommodate bariatric and motorized wheelchairs.

**Rugged, dependable, and easy to store.**

Built with the quality and performance you've come to expect from SR Scales.



Platform size:  
**SR725i - 30" x 32"**  
**SR725iL - 30" x 36"**

### **ANTIMICROBIAL**

SR Scales exclusive: contains Microban<sup>®</sup> antimicrobial technology for powerful, continuous product protection against bacteria.

### **FOLDING DESIGN**

The display mast easily folds down and the platform can be tilted onto the integrated wheels for transport or storage.



### **ALUMINUM PLATE CONSTRUCTION**

Durable and easy-to-clean surfaces.

### **MEMORY RECALL**

Recalls the last stored weight.

### **BATTERY OPERATED**

6 common "D" cell batteries provide approximately 10,000 weigh cycles with programmable Auto Power Down (APD) to conserve power.

### **BMI CALCULATION**

Enter height information to calculate and display Body Mass Index.

### **EHR/EMR READY**

Serial data output can be used to communicate with electronic health records through send or get commands.

### **OPTIONAL EQUIPMENT**

Thermal printer



4 YEAR  
WARRANTY



EASY TRANSPORT  
& STORAGE



MADE IN  
THE USA

# Wheelchair Scale

## Model SR725i and SR725i-L



### SYSTEM SPECIFICATIONS

|                                 |  |
|---------------------------------|--|
| <b>MAX WEIGHT</b>               | 1000 Lb / 454 Kg   |
| <b>DISPLAY TYPE</b>             | 16 Character LCD w/LED Backlight   |
| <b>DISPLAY RESOLUTION</b>       | 0.1 Lb/Kg  |
| <b>ACCURACY</b>                 | 0.1% +/-1 digit of displayed resolution  |
| <b>DISPLAY UNITS</b>            | Pounds/Kilograms   |
| <b>POWER</b>                    | 6 "D" cell alkaline batteries  |
| <b>BATTERY LIFE</b>             | 10,000 Weigh Cycles<br>(est. based on 30 second on-time)   |
| <b>AUTO POWER DOWN (APD)</b>    | Programmable on-time to conserve battery life. A low battery indication will appear when it's time to replace the batteries. |
| <b>MEMORY</b>                   | Last stable weight is automatically stored in memory. Press RECALL to retrieve.  |
| <b>BMI CALCULATION</b>          | Press BMI and input height. Press ENTER to view BMI information.   |
| <b>SERIAL DATA OUTPUT (EHR)</b> | 9-pin serial data output can be used to send weight data to optional printer or EHR/EMR Systems.                             |
| <b>ANTIMICROBIAL</b>            | See <a href="http://www.mircroban.com/sr-scales">www.mircroban.com/sr-scales</a> for specifications on Microban® technology  |
| <b>WARRANTY</b>                 | 4 years  |

### ACCESSORIES AND OPTIONS

| DESCRIPTION   | PART NUMBER             |
|---|-------------------------|
| <b>PRINTER KIT</b><br>(Includes FRAP1300, FRTP130012C, FRBC1300, SE8294, and all mounting hardware) | SR8219                  |
| <b>KILOGRAM ONLY SCALE</b>  | SR725i-KG<br>SR725i-LKG |
| <b>REPLACEMENT THERMAL PRINTER</b>  | FRAP1300                |
| <b>REPLACEMENT PAPER</b><br>(10 rolls per box)  | FRTP130012C             |
| <b>REPLACEMENT PRINTER POWER ADAPTER</b>  | FRBC1300                |

### DIMENSIONS in [cm]

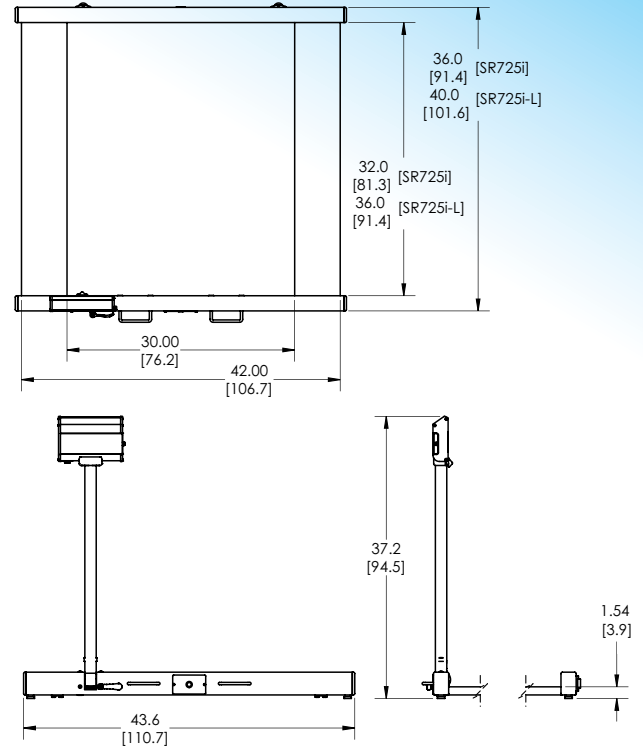

### PACKAGING

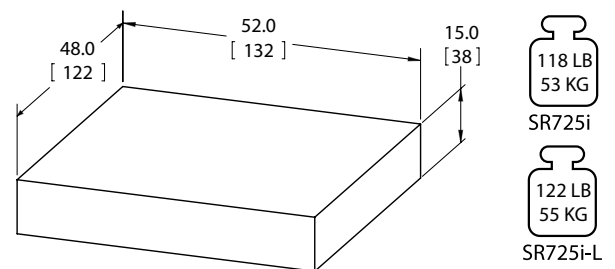

### PRODUCT OPTIONS

| DESCRIPTION                           | PART NUMBER |
|---------------------------------------|-------------|
| <b>30 (76.2) X 36 (91.4) PLATFORM</b> | SR725i-L    |
| <b>30 (76.2) X 32 (81.3) PLATFORM</b> | SR725i      |