

SR Scales®

by **SR** Instruments, Inc.

Model SR555i



Stand-On Scale System

Operating and Service Manual

TABLE OF CONTENTS

TABLE OF FIGURES.....	2
PACKING CHECKLIST.....	3
ASSEMBLY.....	4
REPLACEMENT PARTS AND ACCESSORIES	7
SYSTEM DESCRIPTION AND INTENDED USE.....	7
MICROBAN ANTIMICROBIAL PROTECTION.....	8
MAINTENANCE AND CLEANING.....	8
STORAGE AND TRANSPORTATION	8
SPECIFICATIONS.....	9
BUTTON FUNCTIONS	10
BASIC SYSTEM OPERATION.....	11
BATTERY REPLACEMENT	13
THEORY OF OPERATION	14
CALIBRATION.....	15
CONFIGURING SEND BUTTON.....	17
TROUBLESHOOTING	18
WARRANTY.....	19

TABLE OF FIGURES

Figure 1: Assembly Diagram	4
Figure 2: Cable Clamp and Display Cable Connector	5
Figure 3: Battery Compartment Cover	5
Figure 4: Handrail/Height Bar Diagram	6
Figure 5: Printer Mounting Collar.....	6
Figure 6: Printer Mounting Bracket.....	6
Figure 7: Button Display	10
Figure 8: Bottom of Scale Base	13
Figure 9: Calibration Tolerance Table	15
Figure 10: Calibration Switch Diagram	15

PACKING CHECKLIST

SR555i Stand-On Scale

√	DESCRIPTION	QUANTITY
	Box 1	
	BASE ASSEMBLY (FIVE (5) SET SCREWS IN PLACE)	1 ea
	MAST	1 ea
	DISPLAY UNIT WITH CABLE (FIVE (5) SET SCREWS IN PLACE)	1 ea
	PACKAGE OF SIX (6) "C" CELL BATTERIES	1 ea
	LOCTITE®	1 ea
	1/8" ALLEN WRENCH	1 ea
	QC INSPECTION SHEET	1 ea
	CALIBRATION CERTIFICATE	1 ea
	WARRANTY CARD	1 ea
	MANUAL	1 ea
	Box 2 Optional Handrail and/or Optional Height Bar	
	OPTIONAL HANDRAIL SET WITH HARDWARE	1 ea
	OPTIONAL HEIGHT BAR	1 ea
	Box 3 SR8219 Optional Printer Kit	
	PRINTER	1 ea
	PRINTER BATTERY CHARGER	1 ea
	PRINTER CABLE	1 ea
	PRINTER MOUNTING COLLAR& HARDWARE	1 ea
	PRINTER MOUNTING BRACKET & HARDWARE	1 ea
	PRINTER PAPER	1 ea
	LOCTITE®	1 ea

ASSEMBLY

#	PART NAME
1	Display Unit
2	Base Assembly
3	Mast
4	Cable Clamp
5	Display Cable Connector
6	Handrails (optional)
7	Height Bar (optional)
8	Battery Compartment
9	Printer (optional)
10	Printer Cable (optional)
11	Printer Mounting Collar (optional)

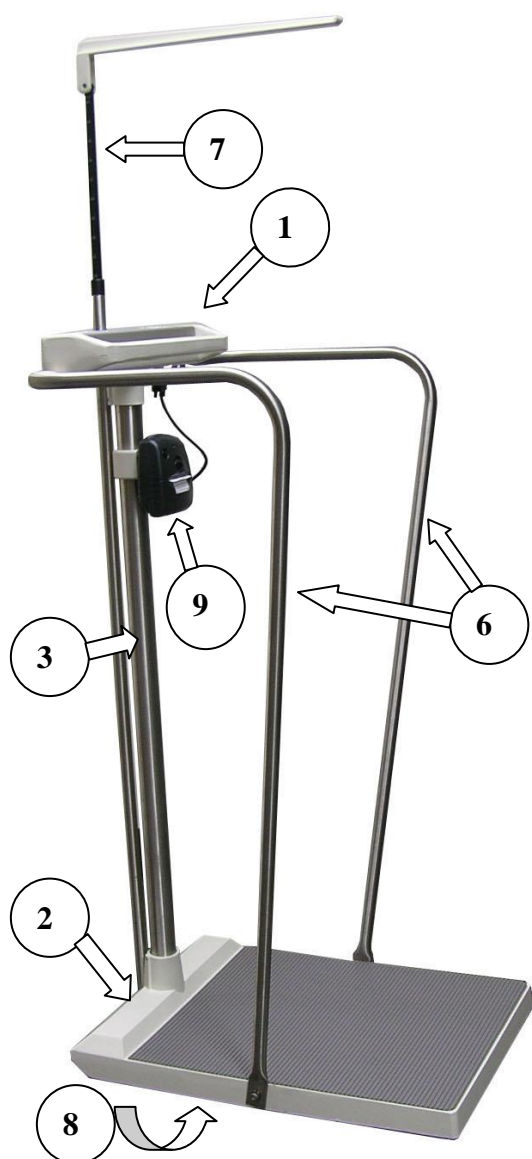

Figure 1: Assembly Diagram

STEP 1: Unpack the scale system and check parts against the **PACKING CHECKLIST**. If there are any missing or damaged parts, please call the service hotline at 1-800-654-6360.

STEP 2: (Figure 1) Verify that the serial number on the Display Unit (1) matches that on the Base Assembly (2).

STEP 3: Remove the four (4) set screws from Base Assembly collar and apply a small amount of Loctite® to each. Insert Mast (3) into Base Assembly collar and seat firmly. Re-install set screws in Base Assembly collar and tighten securely.

NOTE: If an optional printer has been ordered, go to Page 6 “**INSTALLING OPTIONAL PRINTER**” before proceeding.

STEP 4: Feed the display cable down through the Mast and pull out through the Base Assembly.

STEP 5: Remove the set screws from the Display Unit collar. Set the Display Unit squarely on top of the Mast with the display label facing the scale platform. Apply a small amount of Loctite® to the four (4) set screws and reinstall the set screws, tightening securely.

Continued next page

ASSEMBLY cont'd

STEP 6: (Figure 2) Lay the system on its side and remove the Cable Clamp (4) from the Base Assembly. Attach the Display Cable Connector (5) to its mate from the Base Assembly.

STEP 7: (Figure 2) **IMPORTANT:** Reinstall the Cable Clamp! Slide the cable back up into the Mast. Set the display cable into the groove under the Cable Clamp and reinstall the Cable Clamp, leaving just enough slack to alleviate any tension on the Cable exiting the Platform. Securely tighten the Cable Clamp screw. Excess cable **MUST NOT** contact the floor.

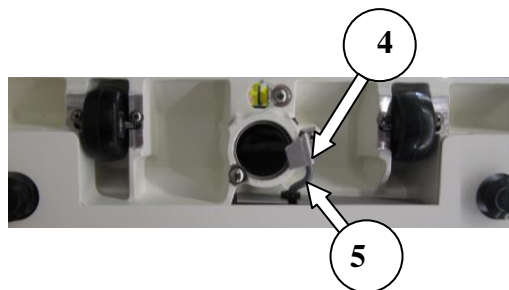

Figure 2: Cable Clamp and Display Cable Connector

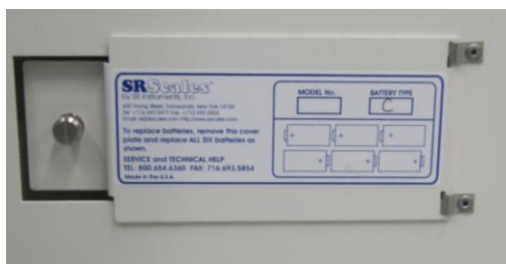

Figure 3: Battery Compartment Cover

STEP 8: (Figure 3) Open the Battery Compartment cover and install the six (6) supplied "C" cell batteries as indicated on the cover diagram. Close the cover and tighten thumb screw.

STEP 9: Return the scale to the upright position.

Continued next page

ASSEMBLY cont'd

INSTALLING OPTIONAL HANDRAILS

STEP 1: (Figure 4) Attach top of each of the Handrails (6) to the bottom right and left of the Display Unit (1). Use two (2) screws and two (2) split-lock washers on each side; slightly tighten. (Do not tighten all of the way.)

STEP 2: Attach the bottom of the Handrails to the right and left side of the Base Assembly (2) using one (1) screw and one (1) split-lock washer for each handrail. Tighten all six (6) screws securely.

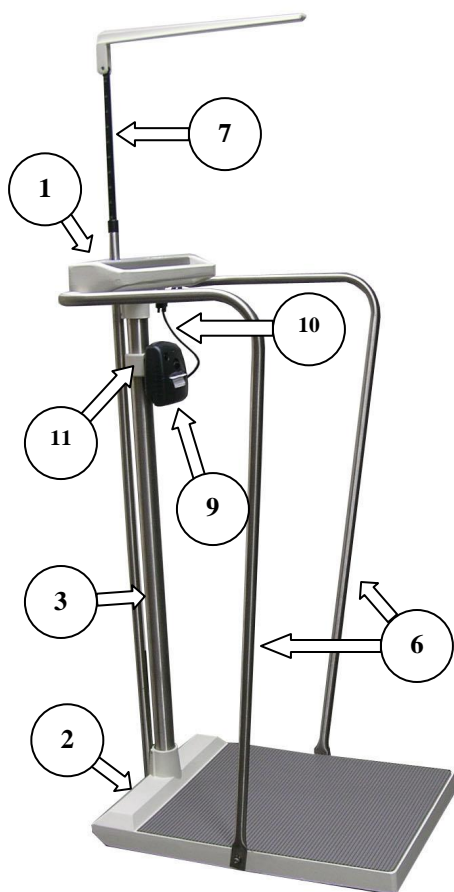

Figure 4: Handrail/Height Bar Diagram

INSTALLING OPTIONAL HEIGHT BAR

STEP 1: (Figure 4) Remove the set screw on the back of the Display Unit (1) and in the Base Assembly (2).

STEP 2: Slide the Height Bar (7) down through the hole in the Display Unit and seat firmly into the Base Assembly. Apply a small amount of Loctite® to the two (2) set screws and reinstall, tightening securely.

INSTALLING OPTIONAL PRINTER

STEP 1: (Figure 4) Slide the Printer Mounting Collar (11) over the Mast (3). Position the Printer Mounting Collar approximately 5 inches from the top of the mast. Tighten the two (2) set screws to secure the Printer Mounting Collar to the Mast. **NOTE:** The three (3) holes on the Printer Mounting Collar should be towards the top of the Mast (Figure 5).

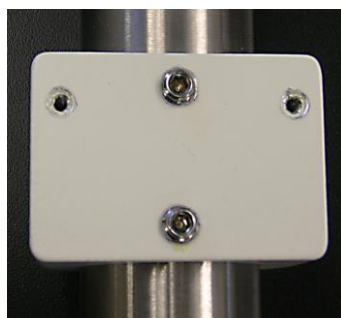

Figure 5: Printer Mounting Collar



Figure 6: Printer Mounting Bracket

Continued next page

ASSEMBLY cont'd

STEP 2: Apply a small amount of Loctite® to the two small screws and attached the Printer Mounting Bracket to the Printer Mounting Collar. (Figure 6).

STEP 3: Attach the Printer to the Printer Mounting Bracket.

STEP 4: After the Display Unit (1) is installed, refer to page 4, plug the Printer Cable (10) into the Printer and into the connector on the bottom of the Display Unit; tighten Printer Cable screws.

REPLACEMENT PARTS and ACCESSORIES

Part #	Description
SR3070	Handrail Set with assembly hardware
SR3086MB	Height Bar: Extends from 43 in to 79 in (109 cm to 201 cm)
SR8219	Printer Kit (optional; contains all printer parts listed below)
FRAP1300	Printer
FRAP1300BR-01	Printer Mounting Bracket
FRAP1300-D9	Printer Cable
FRAP1300PCC	AAA Battery Holder
FRAP1300BP01	Rechargeable Battery Pack
FRTP130012C	Paper, thermal printer 58mm (10 rolls)
FRBC1300	Printer Battery Charger
MF8209	Printer Mounting Collar

SYSTEM DESCRIPTION and INTENDED USE

SYSTEM DESCRIPTION

The SR555i Stand-On Scale System employs the latest in microprocessor and load cell technology to provide accurate and repeatable weight data. Four (4) identically matched transducers are strategically placed to ensure an accurate representation of the patient's weight.

The low power microprocessor circuitry allows the SR555i to derive its power from six (6) common "C" cell batteries that will provide up to 10,000 weight readings before needing replacement. This eliminates the need for an external battery charger or the danger of an AC power supply cord on a portable scale.

The patient's weight is displayed on a 16-character dot matrix LCD. The weight data may be viewed, in either pounds or kilograms, with a displayed resolution of 0.1 for each.

Continued next page

SYSTEM DESCRIPTION and INTENDED USE cont'd

INTENDED USE

The SR555i Stand-On Scale System is specifically designed for use as a stand-on scale for weighing ambulatory patients. Optional equipment includes a Handrail Set, Height Bar, and Printer. SR555i Stand-On Scale System is a preferred means of gathering patient weight data of ambulatory patients weighing up to 1000 pounds or 454 kilograms.



MICROBAN ANTIMICROBIAL PROTECTION

Microban® antimicrobial technology has been added to help reduce the growth of bacteria as part of a medical center's approach to creating a cleaner healthcare environment. For more information, visit <https://www.microban.com/sr-scales>

MAINTENANCE and CLEANING

SR555i Stand-On Scale System is made of a powder-coated aluminum casting with a stainless steel riser post. Exercise caution when cleaning the display window as it is made of clear polyester and can be scratched by abrasive cleaners. Mild soap and water is recommended for general cleaning and disinfecting.

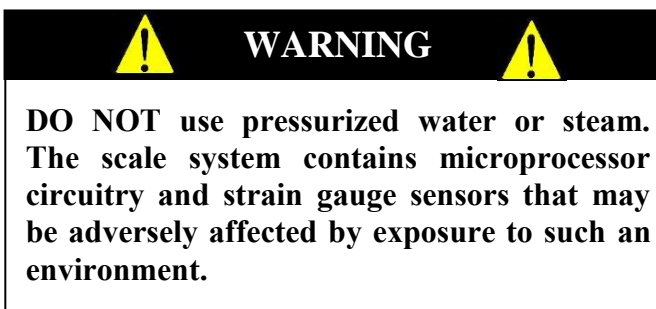

STORAGE and TRANSPORTATION

STORAGE

If storing this equipment for periods longer than three (3) months, remove the batteries. To maintain proper operation of this instrumentation, storage and transport conditions should not vary outside the following conditions: Relative Humidity 0% to 85%, Ambient Temperature 14°F to 122°F (-10°C to +50°C).

TRANSPORTATION

To transport the SR555i, lower the Height Bar, if included, tilt the scale back and wheel to the new location. Lower the platform back down to the floor being careful not to shock the scale.

SPECIFICATIONS

MAXIMUM WEIGHT CAPACITY	1000 lb or 454 kg
PLATFORM SIZE	15 3/4 in x 18 1/2 in (40 cm x 47 cm)
DISPLAY TYPE	16-Character Dot-Matrix LCD
DISPLAY RESOLUTION	0.1 lb / 0.1 kg
ACCURACY	0.1% +/- 1 digit of displayed resolution for calibrated range
AUTO ZERO	One button operation
AUTO POWER DOWN	Approximately 30 seconds (adjustable to 300 seconds)
ENTER	Stores displayed reading in memory
RECALL	Recalls last stored stable weight, height, and BMI
AVERAGING	Automatic digital filter
POWER SUPPLY	Six (6) "C" cell batteries Low battery indicator on Display
CALIBRATION	Calibration is traceable to NIST standards.
OPERATING CONDITIONS	Normal operating conditions for this product: Ambient Temperature Range: 68°F to 85°F (20°C to 30°C) Relative Humidity Range: 0%-85% Avoid exposure to high-pressure water or steam.
TRANSPORTATION and STORAGE	Storage and transportation conditions should not vary outside the following conditions: Relative Humidity 0% to 85%, Ambient Temperature 14°F to 122°F (-10°C to +50°C). Remove batteries if storing longer than three (3) months.

BUTTON FUNCTIONS



Figure 7: Button Display

ZERO / WEIGH



Press and hold to zero. The display will read “**WT = 0.0 Lb**”. This is used to zero the system before placing the patient on the scale system. This action also resets previously stored weight, height and BMI values to zero. Ensure that nothing is in contact with the weighing surface during this procedure.

Press to weigh. Weight stable indicator “” flashes then remains solid when stable. Auto stores stable weight in memory.

SEND (PRINTER / EHR)



Press to send stored values to EHR or to printer. Output values include time, date, weight, height, and BMI. Also, indicated on display when paper is out, “**PAPER OUT**” and when door is open, “**PAPER DOOR OPEN**”.

RECALL



Press to recall the last stable weight. Display will scroll thru “**WT**”, “**HT**”, and “**BMI**” stored values in approximately two second intervals.

ENTER



Press to save height data and display BMI calculation. Stable weight, height and BMI values are stored in memory until next stable weight is stored or until system is zeroed.

BMI



Press to calculate the BMI. When the “**BMI**” is pressed, the default starting value “**HT = 65 in**” or “**HT = 165 cm**” is displayed. If there is no stored stable weight, the display will indicate “**NO WEIGHT DATA**” and then go back to the weigh screen “**WT = 0.0 Lb**”.

Continued next page

BUTTON FUNCTIONS cont'd

MENU



Press Menu to edit setup.

Setting the **UNITS**: Use **UP** or **DOWN** arrow buttons to select “Lb” or “Kg”. Press **ENTER** to save changes.

Setting **ON TIME**: Use **UP** or **DOWN** arrow buttons to adjust the “ON TIME”. The “ON TIME” may be set from 30 to 300 seconds in 30 second increments. Press **ENTER** to save changes.

Setting **TIME** and **DATE**: Use the **UP** arrow button to select digit. To change digit use the **DOWN** arrow button. Press **ENTER** to save changes.

NOTE: When selected, the year position defaults to “00”

Configuring scale output: Use the **UP** or **DOWN** arrow buttons to select between **PRINT** and **EHR**. Press **ENTER** to save changes.

Setting printout orientation: Use the **UP** or **DOWN** arrow buttons to select between “**PRINT INVERTED**” and “**PRINT NORMAL**”. Press **ENTER** to save changes.

UP



Press **UP** to adjust height up from the default, to increase the scale’s “on time”, or to select a digit when setting time and date.

DOWN



Press **DOWN** to adjust the height down from the default, to decrease the scale’s “on time”, or to change the value of a selected digit when setting time and date.

BASIC SYSTEM OPERATION

SETTING SYSTEM ZERO



Make sure the scale is free and clear of any obstructions and press and hold the **ZERO / WEIGH** button. The displayed message will indicate “**HOLD TO ZERO**” and count down to zero. Make sure that nothing is in contact with the scale while zeroing the system. In a few seconds, the display will read “**WT = 0.0 Lb**” (or **Kg**). This action also resets previously stored weight, height, and BMI values to zero.

Continued next page

BASIC SYSTEM OPERATION cont'd

WEIGHING



Position the patient on the scale. Press the **ZERO/WEIGH** button. The weight stable indicator “**□**” flashes on the display. When the weight is stable, the weight stable indicator remains solid. The display will indicate the patient’s weight in either pounds or kilograms; example: “**WT = 123.5 Lb**”. The stable weight is auto stored in memory.

NOTE: If patient will be using a cane for support on the scale, place the cane on the scale while zeroing the system. This will ensure that the patient’s NET weight will be displayed. It is recommended that the system be zeroed prior to each new patient.

CALCULATING BMI



Press to calculate BMI.

When the **BMI** button is pressed, the default starting value is set either to 65 in or to 165 cm; example: “**HT = 65 in**”. Use the **UP** or **DOWN** arrows to adjust the default height to the value of the patient’s height.

NOTE: To calculate the BMI, a patient’s stable weight needs be stored as indicated in “**WEIGHING**” above, if no stable weight has not been stored “**NO WEIGHT DATA**” will be displayed and the display will then go back to the weigh screen “**WT = 0.0 Lb**”.

Press **ENTER** to save height data and display BMI calculation. The BMI will be displayed; example: “**BMI = 20.5**”.

RECALLING LAST STABLE WEIGHT



Press to recall last stable weight.

The display will scroll thru “**WT**”, “**HT**”, and “**BMI**” stored values in approximately two second intervals; example: “**RCL WT = 123.5 Lb**”, “**RCL HT = 65 in**” and “**RCL BMI = 20.5**”.

BATTERY REPLACEMENT

⚠ WARNING ⚠

DO NOT remove batteries while scale is on. Allow scale to shut down naturally thru timing out. This prevents possible voltage drain on the printed circuit board coin battery.

STEP 1: The display will read “**CHANGE BATTERIES**”.

STEP 2: (Figure 8) Place the scale on its side and open the battery compartment cover located in the bottom of the scale base.

STEP 3: Remove and replace ALL six (6) “C” cell batteries. Refer to diagram on the battery compartment cover for placement.

STEP 4: Press the “**WEIGH**” button to confirm display is working.

STEP 5: Tightly close the cover.

STEP 6: Zero the system.



Figure 8: Bottom of Scale Base

THEORY OF OPERATION

SR Instruments patient weighing systems are digital scales. Strain-gauge force cells convert the force of an applied weight into an analog signal. This signal is amplified by an operational amplifier and converted to a digital signal by an on-chip analog to digital converter. The digital signal is filtered, converted to appropriate units, and displayed on the liquid crystal display.

Strain-gauge force cells each contain four strain gauges mounted in a full Wheatstone-bridge configuration. These bridges convert the physical movement of the force cell, due to the applied mass on the system, into minute changes in electrical resistance. These changes in resistance produce a voltage difference across the Wheatstone-bridge, which is amplified by the operational amplifier. The amplifier is configured to current sum the output of each cell, with potentiometers serving to normalize the sensitivity (voltage out per unit of weight applied) of each bridge. The offset potentiometer produces a small current, which nulls the output of the amplifier for an unloaded system.

The output of the operational amplifier is digitized by the analog to digital converter. The sigma-delta converter sums a rapid sequence of 0's (0 volts) and 1's (reference voltage) to achieve balance with the input signal from the amplifier.

The micro-controller filters the digital output of the analog to digital converter, subtracts the value saved during the system zero operation and scales the filtered output, and then displays the result on the liquid crystal display. The micro-controller performs a moving-median filter of data for continuous weigh and, for AutoHold; the micro-controller performs checks for signal stability before locking in on the reading. If the data variance is greater than 0.1% in the AutoHold mode, the micro-controller will reset the filter and start a new filtering period.

The micro-controller can be placed in a calibration mode, where the system can be re-calibrated. In the calibration mode, the system slope is calculated from two points (zero and full scale) in the 2-point calibration mode or the slope and change in slope is calculated from three points (zero, half, and full scale) in the 3-point calibration mode.

CALIBRATION

NOTE: Ensure that nothing is in contact with the scale system during this procedure. Remove hands from the system when noting the displayed calibration results.

CHECKING CALIBRATION

STEP 1: Select two (2) known calibrated weights, traceable to NIST.

NOTE: The first weight should be at least 500 pounds (half of the maximum scale capacity). The second weight should be less than half of the first weight. **DO NOT USE** barbells or uncalibrated weights.

STEP 2: Zero the scale by pressing and holding **ZERO / WEIGH** button.

STEP 3: Place the first calibrated weight on the scale. Wait for scale to stabilize; note scale reading. Remove weight.

STEP 4: Place second calibrated weight on scale. Wait for scale to stabilize; note scale reading. Remove weight.

STEP 5: The scale readings for both weights should be within the Calibration Tolerance Table (Figure 9).

CALIBRATION TOLERANCE TABLE		
LOW LIMIT	APPLIED LOAD	HIGH LIMIT
99.9	100.0	100.1
199.8	200.0	200.2
299.7	300.0	300.3
399.6	400.0	400.4
499.5	500.0	500.5
599.4	600.0	600.6
699.3	700.0	700.7
799.2	800.0	800.8
899.1	900.0	900.9
999.0	1000.0	1001.0

Figure 9: Calibration Tolerance Table

! IMPORTANT !

CALIBRATION Qualified service personnel only should perform this procedure. The SR555i load cells have no user serviceable components and should not be tampered with for any reason. Re-calibration is generally not required, but should be verified periodically to ensure accuracy. The recommendation for calibration check is at least once every 12 months, or as individual maintenance policy requires.

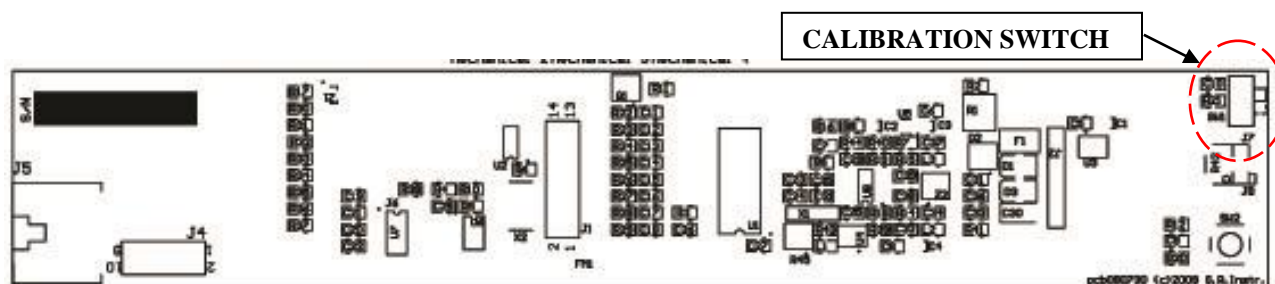
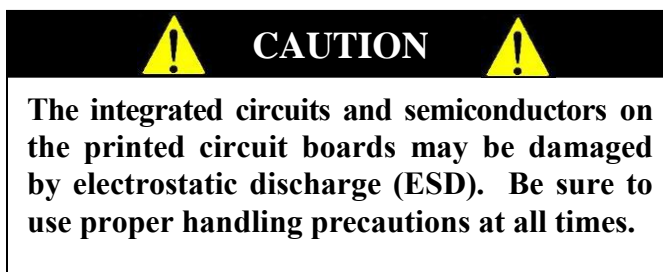

Figure 10: Calibration Switch Diagram

Continued next page

CALIBRATION cont'd



SETTING CALIBRATION

NOTE: Ensure that nothing is in contact with the scale system during this procedure. Remove hands from the system when noting the displayed calibration results.

STEP 1: Remove the four (4) screws on the bottom of the display housing. Lift the display panel. Put the scale system into the Calibration Mode by switching the calibration switch on the display board (Figure 10). “CALIBRATION” will flash on the display.

STEP 2: Select two (2) known calibrated weights, traceable to NIST.

NOTE: The first weight should be at least 500 pounds (half of the maximum scale capacity). The second weight should be less than half of the first weight. **DO NOT USE** barbells or uncalibrated weights.

STEP 3: Press the **MENU** button until “**FULL = 1000.00 Lb**” is displayed. Set the **FULL** value of the first selected calibrated weight. Use the **UP** arrow button to select the digit and the **DOWN** arrow button to change digit. Press **ENTER** to save changes.

STEP 4: Press the **MENU** button until “**HALF = 500.00 Lb**” is displayed. Set the **HALF** value of the second selected calibrated weight. Use the **UP** arrow button to select the digit and the **DOWN** arrow button to change the digit. Press **ENTER** to save changes.

STEP 5: Press **MENU** button until “**3 Pt Calibration**” is displayed. Press the **UP** arrow button.

STEP 6: Zero the scale by removing all weight from the platform. Press the **UP** arrow button.

STEP 7: Place the **HALF** weight from Step 4 on platform. Allow weight to stabilize. Press **UP** arrow to save change. Remove weight.

STEP 8: Place the **FULL** weight from Step 3 on platform. Allow weight to stabilize. Press **UP** arrow to save change. Remove weight.

STEP 9: Press **ENTER** to save the calibration, or **WEIGH** to exit without saving.

STEP 10: Switch the scale system out of the Calibration Mode on the display board (Figure 10).

STEP 11: Place the display panel into the display housing. Align the display panel with the four holes in the display housing. Secure display panel with the four (4) mounting screws.

CONFIGURING SEND BUTTON

STEP 1: Press the “MENU” key until “DATA OUT = PRINT” is displayed

STEP 2: Press “UP” or “DOWN” key to select between “EHR” and “PRINT”

STEP 3: Press the “ENTER” key to save

EHR OUTPUT

Electronic Medical Records (EMR) / Electronic Health Records (EHR) technology is supported by the i-series scales from SR Instruments. The EMR/ EHR software is not included with scale. There are many different EMR/ EHR software available and the connectivity of the scale to the software requires the services of a professional.

A null modem cable is required to communicate with the scale.

Scale output when send button is configured to Electronic Health Records is as follows:

```
<esc>R<esc>Wnnn.n<esc>Hmmm.m<esc>Bkk.k<esc>Uuu<esc>E
```

Where: R is read

W is weight

nnn.n is the weight in Lb or kg

H is height

mmm.m is the height in inches or cm.

B is BMI

kk.k is the BMI

U is units (lb or kg; in or cm)

uu is LB or KG

E is end of packet.

TROUBLESHOOTING

SYMPTOM	REASON/CORRECTIVE ACTION
The characters only appear on half of the display.	Press the “ WEIGH ” button or remove one battery. Wait five seconds, then re-install the battery and try the “ WEIGH ” button again.
The display lights appear to work, but do not respond to button activation.	Check to ensure the membrane switch label is correctly plugged into display board. Check to ensure the calibration switch is not in the Calibration Mode (Figure 10).
The display shows no reading at all.	Check to ensure batteries are installed correctly (see directions for BATTERY REPLACEMENT). Check display cable to make sure it is connected securely.
For additional information or assistance, telephone our Service Hotline: 1-800-654-6360 or e-mail: sri@srinstruments.com	

WARRANTY

FOUR YEAR LIMITED WARRANTY

Each **SR Scales**[®] system is manufactured with high quality components. SR Instruments, Inc. warrants that all new equipment will be free from defects in material or workmanship, under normal use and service, for a period of four (4) years from the date of purchase by the original purchaser. Normal wear and tear, injury by natural forces, user neglect, and purposeful destruction are not covered by this warranty. Warranty service must be performed by the factory or an authorized repair station. Service provided on equipment returned to the factory or authorized repair station includes labor to replace defective parts. Goods returned must be shipped with transportation and/or broker charges prepaid. SR Instruments, Inc.'s obligation is limited to replacement of parts that have been so returned and are disclosed to SR Instruments, Inc.'s satisfaction to be defective. The provisions of this warranty clause are in lieu of all other warranties, expressed or implied, and of all other obligations or liabilities on SR Instruments, Inc.'s part, and it neither assumes nor authorizes any other person to assume for SR Instruments, Inc. any other liabilities in connection with the sale of said articles. In no event shall SR Instruments, Inc. be liable for any subsequent or special damages. Any misuse, improper installation, or tampering, shall void this warranty.

DAMAGED SHIPMENTS

Title passes to purchaser upon delivery to Transportation Company. Any claims for shortage or damage should be filed with the delivery carrier by purchaser.

RETURN POLICY

All products being returned to SR Instruments, Inc. require a Return Goods Authorization number (RGA). To receive an RGA, call our Technical Service Team at 716-693-5977 or toll-free in the USA and Canada at 800-654-6360.

When inquiry is made, please supply model and serial numbers, purchase order, if the scale was bought on contract, and reason for return.

Generally, deleted, damaged, and outdated merchandise will not be accepted for credit. A minimum restocking charge of 15% will be assessed on return of current merchandise.

All returns are to be shipped **FREIGHT PREPAID** to: SR Instruments, Inc., 600 Young Street, Tonawanda, NY 14150.

RESTOCKING FEE

- **15% fee** for any scale that has been opened and used
- **10% fee** for any scale returned that has been ordered incorrectly or refused delivery with no model change
- **5% fee** if an error in ordering has been made and a different model exchanged
- **No fees** will be charged if the scale is returned because of an error on the part of SR Instruments, Inc.
- **No returns** accepted after 60 days.

SR Scales[®]

by **SR**[®] Instruments, Inc.

**Precision & Technology in
Perfect Balance**[®]