SR Scales®

by **SR** Instruments, Inc.

Model SR630i



Pediatric Scale

Operating and Service Manual

TABLE OF CONTENTS

TABLE OF FIGURES.....	2
PACKING CHECKLIST - MODEL SR630I.....	3
PACKING CHECKLIST - MODEL SR635I.....	4
SR630I ASSEMBLY.....	5
SR635I CART ASSEMBLY	6
REPLACEMENT PARTS AND ACCESSORIES	7
SYSTEM DESCRIPTION AND INTENDED USE.....	8
MICROBAN ANTIMICROBIAL PROTECTION.....	8
MAINTENANCE AND CLEANING.....	9
STORAGE AND TRANSPORTATION	9
SPECIFICATIONS.....	10
BUTTON FUNCTIONS	11
BATTERY REPLACEMENT	13
THEORY OF OPERATION	13
CALIBRATION.....	15
TROUBLESHOOTING	17
WARRANTY.....	18
NOTES.....	19

TABLE OF FIGURES

Figure 1: Pediatric Scale Packing List.....	3
Figure 1: Pediatric Scale with Cart Packing List	4
Figure 3: Battery Compartment Location.....	5
Figure 4: Cart Assembly	6
Figure 5: Scale Mounting Scale Location	7
Figure 6: Battery Compartment Location.....	7
Figure 7: Button Display Label	11
Figure 8: Battery Replacement.....	13
Figure 9: Calibration	15
Figure 10: Calibration Switch Location	16

PACKING CHECKLIST - Model SR630i Pediatric Scale

√	DESCRIPTION	QUANTITY
	SCALE BASE	1 ea
	AC POWER SUPPLY	1 ea
	PACKAGE OF SIX (6) D-CELL BATTERIES (INSTALLED)	6 ea
	CALIBRATION CERTIFICATE	1 ea
	WARRANTY CARD	1 ea
	MANUAL	1 ea

**Figure 1: Pediatric Scale
Packing List**

PACKING CHECKLIST - Model SR635i Pediatric Scale with Cart

√	DESCRIPTION	QUANTITY
	SCALE BASE	1 ea
	AC POWER SUPPLY	1 ea
	PACKAGE OF SIX (6) D-CELL BATTERIES (INSTALLED)	6 ea
	CALIBRATION CERTIFICATE	1 ea
	WARRANTY CARD	1 ea
	MANUAL	1 ea
	SM9362 CART KIT- BOX MAY SHIP SEPARATE	QUANTITY
	INNER TUBE ASSEMBLY WITH CASTER	2 ea
	INNER TUBE ASSEMBLY WITH LOCKING CASTER	2 ea
	OUTER SPACER TUBE – 3”	4 ea
	OUTER SPACER TUBE – 13”	4 ea
	OUTER SPACER TUBE – 10.25”	4 ea
	SHELF ASSEMBLY	2 ea
	TOP MOUNTING PLATE	2 ea
	¼-20 X 1” SOCKET BUTTON HEAD SCREW	8 ea

**Figure 2: Pediatric Scale with Cart
 Packing List**

SR630i ASSEMBLY

- STEP 1:** Unpack scale system and check parts against **PACKING CHECKLIST**. If there are any missing or damaged parts, please call Service Hotline 1-800-654-6360. Allow scale to acclimate to room temperature before use.
- STEP 2:** (Figure 3) Install the six (6) “D” cell batteries into the Battery Compartment on underside of scale. Attach the Battery Compartment Cover using the two (2) cover screws. Screw cover down securely to Scale Base.
- If batteries shipped installed, leave battery cover installed and remove insulator strip (clear polyester strip extending from battery compartment).
- STEP 3:** (Figure 3) Place the Scale onto tabletop. Connect AC Power supply between scale and Wall Outlet and press “**ZERO**” button to activate scale.



Figure 3: Battery Compartment Location

SR635i CART ASSEMBLY

- STEP 1:** Unpack scale system and check parts against **PACKING CHECKLIST**. If there are any missing or damaged parts, please call Service Hotline 1-800-654-6360. Allow scale to acclimate to room temperature before use.
- STEP 2:** Remove shipping washers from inner support tubes and discard
(DO NOT DISCARD button head screws - used in Step 9)
- STEP 3:** Remove the 10.25" and 13" tubes from each inner support tube
- STEP 4:** Place one shelf over an inner support tube with a locking caster
- STEP 5:** Place one 13" tube over the inner support tube
- STEP 6:** Place one shelf over the inner support tube
- STEP 7:** Place one 10.25" tube over the inner support tube
- STEP 8:** Complete the next assembly on the same end using one inner support tube assembly with a caster
- STEP 9:** Secure the top plate to both inner support tubes using the 1/4-20 x 1" button head screws
- STEP 10:** Complete other side in the same manner making sure that both locking caster are in front
- STEP 11:** Make sure that all four screws are tight

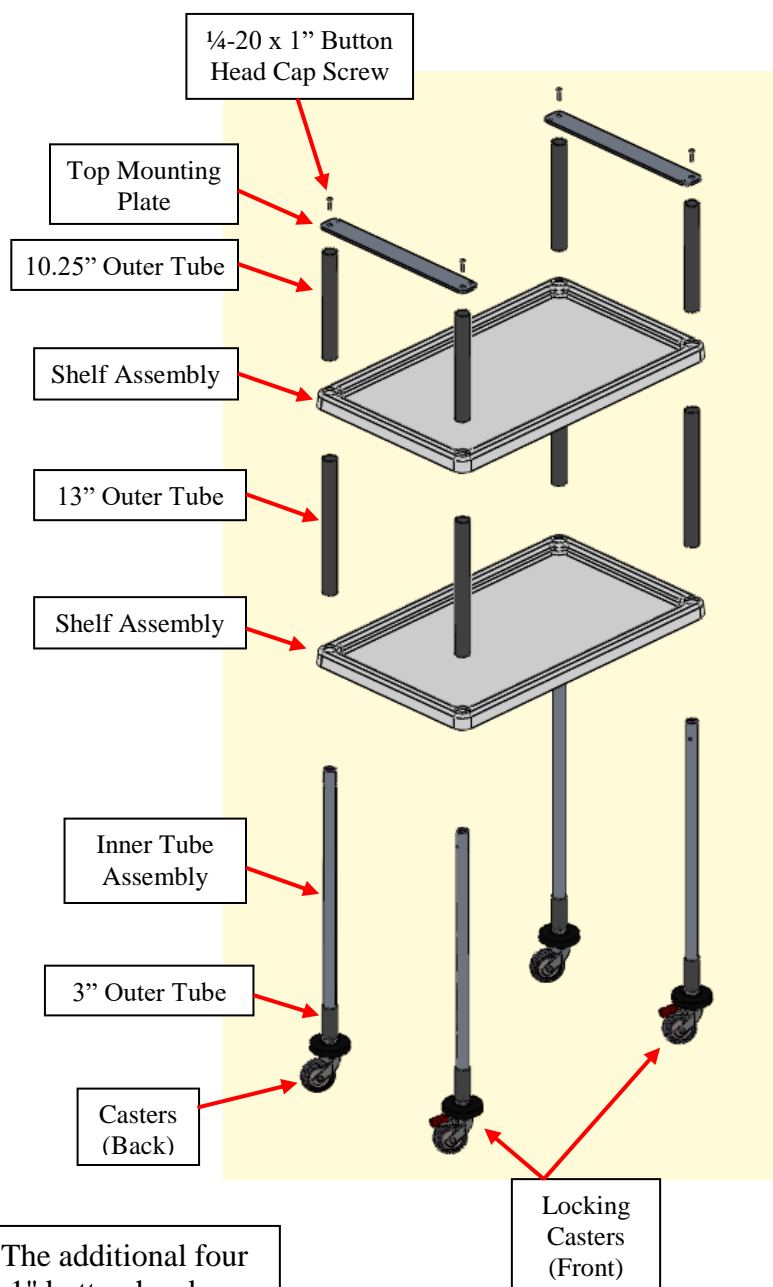
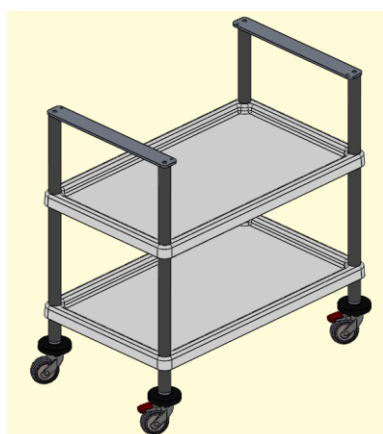

NOTE: The additional four 1/4-20 x 1" button head screws are for mounting the Pediatric Scale to the cart

Figure 4: Cart Assembly

CART ASSEMBLY (CON'T)

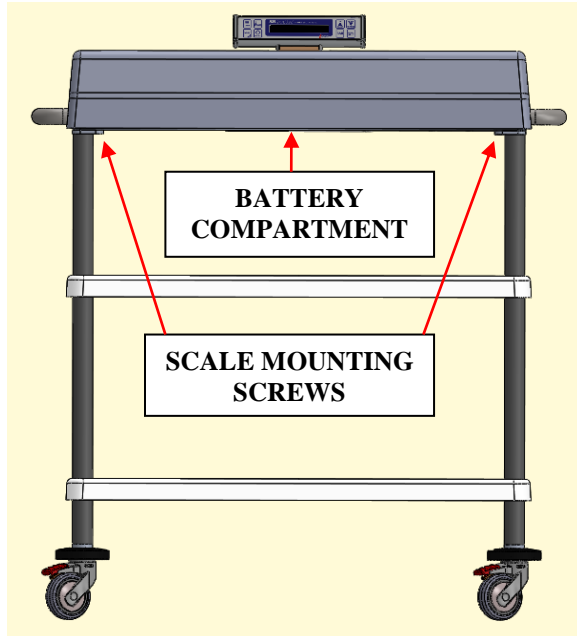

Figure 6: Battery Compartment Location



Figure 5: Scale Mounting Scale Location

STEP 12: Remove the four feet from the corners of the scale (Figure 5). Retain feet if scale may again be used as table-top version.

STEP 13: (Figure 5 & Figure 3) Place the Scale on top of the cart, aligning threaded holes on underside of scale with the holes on the Top Plate. Ensure the Display is located to the back of the cart, on the opposite side of the locking casters (Figure 4). Attach scale using four (4) ¼-20 X 1” mounting screws.

REPLACEMENT PARTS and ACCESSORIES

Part #	Description
FRGSM06U09P1J	AC POWER SUPPLY
FBM1012000	REPLACEMENT FOOT
SM9362	TRANSPORT CART (OPTIONAL)

SYSTEM DESCRIPTION and INTENDED USE

SYSTEM DESCRIPTION

The SR630i Pediatric Scale employs the latest in microprocessor and load cell technology to provide accurate and repeatable weight data. Four (4) identically matched transducers are strategically placed to ensure an accurate representation of the child's weight regardless of weight distribution.

The child's weight is displayed in pounds, ounces, kilograms, or grams on a 16-character dot matrix LCD. The displayed resolution is 0.01 lb., 1/4 oz., 0.005 kg, and 5 g.

INTENDED USE

The SR630i Pediatric Scale is designed for use in pediatric applications and is not intended as a patient transport device. Maximum weight capacity must not exceed 44 pounds or 20 kilograms gross weight.

The cart included with the SR635i Pediatric Scale is designed for moving the scale without a patient from one location to another. This is not intended as a patient transport device. Maximum weight capacity must not exceed 44 pounds or 20 kilograms gross weight.



MICROBAN ANTIMICROBIAL PROTECTION

Microban® antimicrobial technology has been added to help reduce the growth of bacteria as part of a medical center's approach to creating a cleaner healthcare environment. For more information, visit <https://www.microban.com/sr-scales>

MAINTENANCE and CLEANING

Exercise caution when cleaning the display window and pediatric cradle as both can be scratched by abrasive cleaners. Mild soap and water is recommended for general cleaning.

CLEANING

To clean pediatric cradle:

- Dissolve mild liquid detergent in cool water.
- Dip soft, clean cloth in solution and wring out.
- Wipe the surface of the sheet.
- Allow surface to dry naturally, or wipe with a separate cloth slightly dampened with solution.

DISINFECTION

To disinfect pediatric cradle:

- Dilute an antiseptic or hospital concentrate with cool or cold water in the amount recommended on the label for general disinfection.
- Wipe the surface as described under CLEANING.

The disinfectant solution with 1% sodium hypochlorite and/or isopropyl alcohol causes no apparent damage on hardness and roughness of pediatric cradle.

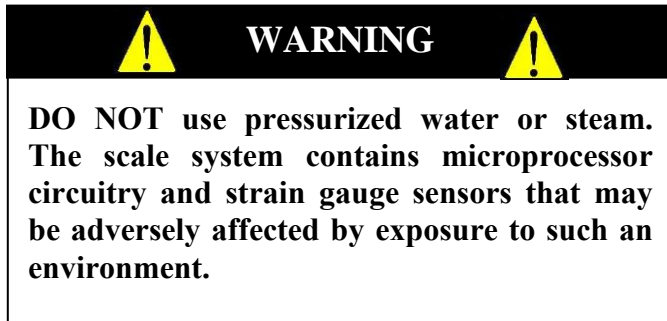

STORAGE and TRANSPORTATION

If storing this equipment for periods longer than three (3) months, remove the batteries. To maintain proper operation of this instrument, storage and transport conditions should not vary outside the following conditions: Relative Humidity 0% to 85%, Ambient Temperature 14°F to 122°F (-10°C to +50°C).

Prior to use, allow scale to acclimate to room temperature.

The cart included with the SR635i Pediatric Scale is designed for moving the scale without a patient from one location to another. This is not intended as a patient transport device. Maximum weight capacity must not exceed 44 pounds or 20 kilograms gross weight.

SPECIFICATIONS

MAXIMUM WEIGHT CAPACITY	44 lb or 20 kg
CRADLE SIZE	29 1/2 in x 13 1/2 in (75 cm x 34 cm)
DISPLAY TYPE	16-Character Dot-Matrix LCD
DISPLAY RESOLUTION	0.01 lb, 1/4 oz., 0.005 kg, 5 g
ACCURACY	0.1% +/- 1 digit of displayed resolution for calibration range
AUTO ZERO	One button operation
AUTO POWER DOWN	Approximately 30 seconds
LAST WEIGHT RECALL	Press "RECALL" button to recall last stored displayed reading
AVERAGING	Automatic digital filter
POWER SUPPLY	Six (6) "D" cell batteries Medical Grade AC Wall Power Supply
CALIBRATION	Calibration is traceable to NIST standards
OPERATING CONDITIONS	Normal operating conditions for this product: Ambient Temperature Range: 68°F to 85°F (20°C to 30°C) Relative Humidity Range: 0% to 85% Avoid exposure to high-pressure water or steam.
TRANSPORTATION and STORAGE	Storage and transportation conditions should not vary outside the following conditions: Relative Humidity 0% to 85%, Ambient Temperature 14°F to 122°F (-10°C to +50°C). Remove batteries if storing longer than three (3) months. Prior to use, allow scale to acclimate to room temperature. Never transport a patient on the scale. Cart is meant for scale transport only.

BUTTON FUNCTIONS



Figure 7: Button Display Label

ZERO



Press to zero. The display will read “**0.00 Lb**”. This is used to zero the system before placing the patient on the scale system. This action also resets previously stored weight values to zero. Ensure that nothing is in contact with the molded plastic cradle during this procedure.

SEND



“**SEND**” button requires additional set up.
Contact SR Instruments, Inc for further details.

RECALL



Press to recall the last stable weight.

ENTER



Press to save changes to “**MENU**” options.

Continued next page

BUTTON FUNCTIONS (CON'T)

MENU



Press Menu to edit setup.

Setting the **UNITS**: Use **UP** or **DOWN** arrow buttons to select “Lb”, “Kg” “Lb/oz” or “g” Press **ENTER** to save changes.

Setting **ON TIME**: Use **UP** or **DOWN** arrow buttons to adjust the “ON TIME”. The “ON TIME” may be set from 30 to 300 seconds in 30 second increments. Press **ENTER** to save changes.

Configuring scale output: Not available.

Setting **TIME** and **DATE**: Use the **UP** arrow button to select digit. To change digit use the **DOWN** arrow button. Press **ENTER** to save changes.

NOTE: When selected, the year position defaults to “00”

UP



Press **UP** to increase the scale’s “on time” or to select a digit when setting time and date.

DOWN



Press **DOWN** to decrease the scale’s “on time” or to change the value of a selected digit when setting time and date.

BASIC SYSTEM OPERATION

SETTING SYSTEM ZERO



Make sure the scale is free and clear of any obstructions or contact and press the “**ZERO**” button with all linens, pads, etc. in place and release.

Wait for the display to display “**0.00 Lb**”. This action also resets previously stored weight to zero.



Continued next page

BASIC SYSTEM OPERATION (CON'T)

WEIGHING



Press to weigh. Weight stable indicator “□” flashes then remains solid when stable. Auto stores stable weight in memory.

Place the child onto the molded plastic cradle. The weight data will be displayed. Press the “WEIGH” button. A stable weight is indicated when the left most segment stops flashing “□” and turns to solid on the display. The display will indicate the child’s weight in pounds; example: “□ WT= 12.35 Lb”. The stable weight is auto stored in memory.

NOTE: If there are any accessories (blanket, diaper, etc.), place them on the scale before zeroing the system. This will ensure that the patient’s NET weight will be displayed. It is recommended that the system be zeroed prior to each new patient.

RECALLING LAST STABLE WEIGHT



Press the recall button will display the last stable weight. A recalled weight will be indicated by “RCL”; for example: “RCL WT 12.35 Lb”.

BATTERY REPLACEMENT

STEP 1: Display will read “REPLACE BATTERIES”.

STEP 2: (Figure 8) Locate Battery Compartment Cover on underside of scale and unscrew the two (2) cover screws.

STEP 3: Remove and replace ALL six (6) “D” cell batteries. Refer to battery compartment cover label for placement.

STEP 4: Replace the Battery Compartment Cover and securely tighten screws.

STEP 5: Press the “ZERO” button to confirm display is working.

STEP 6: Zero the system.



Figure 8: Battery Replacement

THEORY OF OPERATION

SR Instruments patient weighing systems are digital scales. Strain-gauge force cells convert the force of an applied weight into an analog signal. This signal is amplified by an operational amplifier and converted to a digital signal by an analog to digital converter. The digital signal is transferred to a micro-controller where it is filtered, converted to appropriate units and displayed on a liquid crystal display.

Strain-gauge force cells each contain four strain gauges mounted in a full Wheatstone-bridge configuration. These bridges convert the physical movement of the force cell, due to the applied mass on the system, into minute changes in electrical resistance. These changes in resistance produce a voltage difference across the Wheatstone-bridge, which is amplified by the operational amplifier. The amplifier is configured to current sum the output of each cell.

The output of the operational amplifier is digitized by the analog to digital converter. The sigma-delta converter sums a rapid sequence of 0's (0 volts) and 1's (reference voltage) to achieve balance with the input from the amplifier.

The micro-controller averages and filters the digital output of the analog to digital converter, subtracts the value saved during the system zero operation and scales the filtered output, then displays the result on the liquid crystal display. The micro-controller performs a moving-median filter of data for continuous weigh and, for AutoHold, the micro-controller performs checks for signal stability before locking in on the reading. If the data variance is greater than 0.1% in the AutoHold mode, the micro-controller will reset the filter and start a new filtering period.

The micro-controller can be placed in a calibration mode, where the system can be re-calibrated. In the calibration mode, the system slope is calculated from two points (zero and full scale) in the 2-point calibration mode, or the slope and change in slope is calculated from three points (zero, half and full scale) in the 3-point calibration mode.

CALIBRATION

NOTE: Ensure that nothing is in contact with the scale system during this procedure. Remove hands from the system when noting the displayed calibration results.

CHECKING CALIBRATION

STEP 1: Select known calibrated weights (traceable to NIST) adding up to the maximum scale capacity.

NOTE: DO NOT USE barbells or uncalibrated weights.

STEP 2: Zero the scale by pressing the **ZERO** button.

STEP 3: Place the first calibrated weight on the scale. Wait for scale to stabilize; note scale reading.

STEP 4: Repeat STEP 3 up to maximum scale capacity by pressing **WEIGH** button after adding each weight. The scale readings should be within the Calibration Tolerance Table (Figure 9).

STEP 5: Remove weight.

CALIBRATION TOLERANCE TABLE		
LOW LIMIT	APPLIED LOAD (lb)	HIGH LIMIT
1.00	1.00	1.00
5.00	5.00	5.01
9.99	10.00	10.01
14.99	15.00	15.02
19.98	20.00	20.02
24.98	25.00	25.03
29.97	30.00	30.03
34.97	35.00	35.04
39.96	40.00	40.04
43.96	44.00	44.04

**Figure 9: Calibration
Tolerance Table**

CALIBRATION (CON'T)

! IMPORTANT !

CALIBRATION CHECK - Qualified service personnel only should perform this procedure. Load cells have no user serviceable components and should not be tampered with for any reason. Re-calibration is generally not required, but should be verified periodically to ensure accuracy. Recommendation for calibration check is at least once every 12 months, or as individual maintenance policy requires.

! CAUTION !

The integrated circuits and semiconductors on the printed circuit boards may be damaged by electrostatic discharge (ESD). Be sure to use proper handling precautions at all times.

CALIBRATION PROCEDURE

NOTE: Ensure that nothing is in contact with the scale system during this procedure. Remove hands from the system when noting the displayed calibration results.

STEP 1: Remove the three (3) screws from the left side of display housing end cap and remove the end cap. Set end cap and screws aside.

STEP 2: Put the scale system into the Calibration Mode by switching the calibration switch on the display board (Figure 10), “CALIBRATION” will flash on the display.

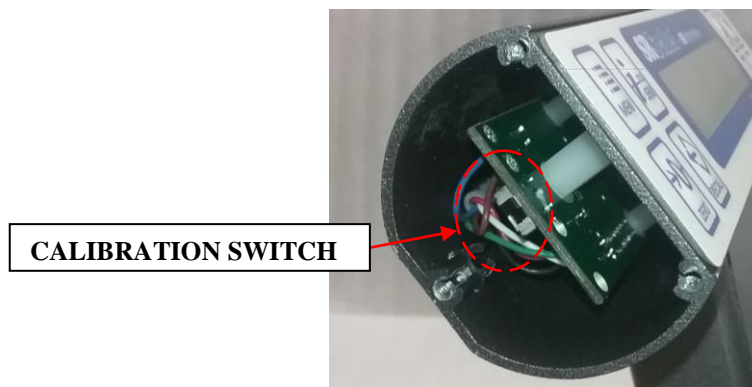

Figure 10: Calibration Switch Location

Continued next page

CALIBRATION cont'd

STEP 3: Select at least two (2) known calibrated weights (traceable to NIST) adding up to the maximum scale capacity.

NOTE: The first weight or group of weights should be half of the maximum scale capacity. The second weight or group of weights should add up to the maximum scale capacity.

DO NOT USE barbells or uncalibrated weights.

STEP 4: Press **MENU** button until “**3 Pt Calibration**” is displayed. Press the **UP** arrow button.

STEP 5: Zero the scale by first removing all weight from the scale and pressing the **UP** arrow button.

STEP 6: Place ten kilograms of calibrated weight, **HALF** the maximum scale capacity on the scale. Allow weight to stabilize. Press **UP** arrow to save change.

STEP 7: Place twenty kilograms of calibrated weight, **FULL** scale of the maximum scale capacity on the scale. Allow weight to stabilize. Press **UP** arrow to save change.

STEP 8: Press **ENTER** to save the calibration, or **WEIGH** to exit without saving.

STEP 9: Switch the scale system out of Calibration Mode on the display board (Figure 10) and replace end cap.

TROUBLESHOOTING

SYMPTOM	REASON/CORRECTIVE ACTION
Low readings	Check offset and verify calibration Ensure the cradle is not contacting the plate under the scale
Only half of display activates	Press the “WEIGH” button
No power	Check that batteries are making contact with each other and the terminals of the battery holder. Ensure AC power supply is firmly plugged in
For additional information or assistance, telephone the Service Hotline: 1-800-654-6360 or e-mail: sri@srinstruments.com	

WARRANTY

FOUR YEAR LIMITED WARRANTY

Each **SR Scales**[®] system is manufactured with high quality components. SR Instruments, Inc. warrants that all new equipment will be free from defects in material or workmanship, under normal use and service, for a period of four (4) years from the date of purchase by the original purchaser. Normal wear and tear, injury by natural forces, user neglect, and purposeful destruction are not covered by this warranty. Warranty service must be performed by the factory or an authorized repair station. Service provided on equipment returned to the factory or authorized repair station includes labor to replace defective parts. Goods returned must be shipped with transportation and/or broker charges prepaid. SR Instruments, Inc.'s obligation is limited to replacement of parts that have been so returned and are disclosed to SR Instruments, Inc.'s satisfaction to be defective. The provisions of this warranty clause are in lieu of all other warranties, expressed or implied, and of all other obligations or liabilities on SR Instruments, Inc.'s part, and it neither assumes nor authorizes any other person to assume for SR Instruments, Inc. any other liabilities in connection with the sale of said articles. In no event shall SR Instruments, Inc. be liable for any subsequent or special damages. Any misuse, improper installation, or tampering, shall void this warranty.

DAMAGED SHIPMENTS

Title passes to purchaser upon delivery to Transportation Company. Any claims for shortage or damage should be filed with the delivery carrier by purchaser.

RETURN POLICY

All products being returned to SR Instruments, Inc. require a Return Goods Authorization number (RGA). To receive an RGA, call our Technical Service Team at 716-693-5977 or toll-free in the USA and Canada at 800-654-6360.

When inquiry is made, please supply model and serial numbers, purchase order, if the scale was bought on contract, and reason for return.

Generally, deleted, damaged, and outdated merchandise will not be accepted for credit. A minimum restocking charge of 15% will be assessed on return of current merchandise.

All returns are to be shipped **FREIGHT PREPAID** to: SR Instruments, Inc., 600 Young Street, Tonawanda, NY 14150.

RESTOCKING FEE

- **15% fee** for any scale that has been opened and used
- **10% fee** for any scale returned that has been ordered incorrectly or refused delivery with no model change
- **5% fee** if an error in ordering has been made and a different model exchanged
- **No fees** will be charged if the scale is returned because of an error on the part of SR Instruments, Inc.
- **No returns** accepted after 60 days

NOTES

SRScales®

By **SR** Instruments, Inc.

**Precision & Technology in
Perfect Balance™**